



Document Nr.: 0003/Jan-2017

*PROJECT RUNE*

*RUNE CORE AND AGGREGATION NETWORK HIGH LEVEL  
DESIGN*

**FINAL ver.1.0**

Date: 20. February 2018

CUSTOMER INFORMATION (PODATKI O STRANKI)	
<b>CUSTOMER:</b> <i>(naročnik)</i>	<b>RUNE RURAL NETWORKS</b> RUNE-SI d.o.o., RUNE-ADRIA d.o.o.
<b>CUSTOMER CONTACT PERSON:</b> <i>(kontaktna oseba naročnika)</i>	Goran Živec, Saša Ukič
<b>CUSTOMER CONTACTS:</b> <i>(kontakt odgovorne osebe)</i>	goran.zivec@ruralnetwork.eu sasa.ukic@ruralnetwork.eu
<b>OTHER CUSTOMER INFORMATION:</b> <i>(drugi podatki o stranki)</i>	www.ruralnetwork.eu
INFORMATION ABOUT HIGL LEVEL DESIGNER	
<b>COMPANY INFO:</b> <i>(osnovni podatki o podjetju)</i>	PROJEKT IP d.o.o. Cesta Marežganskega upora 4 6000 KOPER SLOVENIJA
<b>RESPONSIBLE PERSON CONTACTS:</b> <i>(podatki odgovorne osebe)</i>	egon@projektip.si +386 (0)40 569 570
<b>SCOPE OF THE HLD:</b>	RUNE CORE AND TRANSPORTATION NETWORK

## I. TABLE OF CONTENTS

I.	TABLE OF CONTENTS	3
II.	TABLE OF FIGURES.....	3
III.	GLOSSARY.....	4
1.	CUSTOMER REQUESTS .....	5
1.1	GENERAL CUSTOMER REQUESTS.....	5
1.2	CUSTOMER REQUESTS IN NUMBERS.....	6
1.3	DETAILED TECHNICAL CUSTOMER REQUESTS .....	7
1.4	NETWORK MANAGEMENT/PROVISIONING REQUESTS .....	8
2.	INTRODUCTION INTO PROPOSED SOLUTION .....	9
2.1	INTRODUCTION .....	9
2.1.1	OVERALL AGGREGATION CAPACITY.....	9
2.1.2	OVERALL UPLINK CAPACITY .....	10
2.1.3	INTERFACE TYPE CHOICE.....	10
2.1.4	CORE NETWORK AGGREGATION .....	11
2.1.5	PREDICTED SUBSCRIBERS NUMBER .....	11
2.1.6	TRANSPORTATION LEVEL SERVICES .....	12
2.1.7	AGGREGATION AND CORE NETWORK FUNCTIONS .....	12
2.1.8	ACCESS LAYER SERVICES .....	13
2.2	PROPOSED SOLUTION.....	13
2.2.1	SYSTEM CAPACITY.....	14
2.2.2	CAPACITY PLANNING .....	14
2.2.3	TRANSPORT NETWORK .....	15
2.2.4	NETWORK TOPOLOGY.....	16
2.2.5	REDUNDANCY OF THE PROPOSED SYSTEM .....	18
2.2.6	ISPCN – CORE NODE.....	19
2.2.7	AGGN NODE .....	27
2.2.8	AAN NODE.....	37
2.2.9	OPTICAL TRANSPORT SYSTEM .....	39
2.2.10	MANAGEMENT SYSTEM.....	41
2.2.11	NETWORK MANAGEMENT SYSTEM FEATURES.....	42
2.2.12	MANAGEMENT NETWORK OF ISPCN NODE .....	43
2.2.13	MANAGEMENT NETWORK OF AGGN AND AAN NODE .....	44
2.2.14	END-USER ACCESS MANAGEMENT .....	45
3.	PROJECT SCHEDULE.....	46
4.	ADDENDA .....	47

## II. TABLE OF FIGURES

Figure 1:	Network capacity .....	14
Figure 2:	Network topology - AGGN and ISPCN nodes .....	16
Figure 3:	Region RUNE-SI and RUNE-ADRIA.....	17
Figure 4:	Basic Network Topology.....	19
Figure 5:	ISPCN node .....	20
Figure 6:	ISPCN node interconnect .....	21
Figure 7:	AGGN node interconnect (AD and SD devices).....	28
Figure 8:	AGGN node throughput .....	29
Figure 9:	AAN node interconnect.....	37
Figure 10:	Logical Vertical Network Topology.....	38
Figure 11:	WDM system .....	40
Figure 12:	DWDM topology, each red color link has capacity of 200GE (upgradeable to 400GE).....	41
Figure 13:	Management network ISPCN node.....	43
Figure 14:	Management network AGGN and AAN nodes.....	44

### III. GLOSSARY

AAN	Active Access Node
AGGN	Aggregation Node
AGGN-AD	Aggregation Node – Aggregation Device
AGGN-SD	Aggregation Node – Satellite Device
CD	Core Device
CFP	C-form-factor Pluggable
CVLAN	Customer VLAN
DWDM	Dense Wavelength Division Multiplexing
EVC	Ethernet Virtual Connection
GPON	Gigabit Passive Optical Network
ISPCN	Internet Services Provider Connection Node
ISSU	In-Service System Upgrade
MPLS	Multiprotocol Label Switching
NGA	Next-Generation Access
XGS-PON	Next-Generation Passive Optical Network
OAN	Open Access Network
PON	Passive Optical Network
QSFP	Quad Small Form-factor Pluggable
RFI	Request for Information
SFP	Small Form-factor Pluggable
SVLAN	Service VLAN
UNI	User Network Interface

# 1. CUSTOMER REQUESTS

## 1.1 GENERAL CUSTOMER REQUESTS

Customer (RUNE-SI and RUNE-ADRIA) RUNE wants to build Open Access Network (OAN) based on PON access technology and IP/MPLS based high-speed non-oversubscribed core network. Core of the network will present up-stream/peering connections to the Content Providers and Internet Service Providers from where all services will come to end users – residential and business type.

Provided network solution must be 100% transparent for all services and content providers.

Customer is planning to provide Gigabit Next Generation Access (NGA) network in rural areas of Slovenia and part of Croatia through PON technologies. Access, aggregation and core networks would be built separately in both countries and interconnected through their core networks. Network must be robust, open, and highly available with extremely high performance - line speed is required from CPE device through access network to the access port of Aggregation AGGN Node and to the core network for avoiding any minimal possibility of network congestion and consequently services degradation.

Infrastructure network must be ready:

- For Bit-Stream (L2) services as well
- For IP-Stream (L3) services for each end customer and
- Higher level services (IP/MPLS)

Customer requests are standard requests for this type of network infrastructure, beside request for IP-Stream (L3) services, where proposed solution must take into account several network functionalities for enabling higher level services and consider also support for technologies becoming necessary and real in proposed solution lifecycle (IPV4, IPV6, OTT services,...).

Any solution for backbone and transportation network must consider all the following restraints and considerations:

- As few active points as possible
- Network scalability and possible growth
- Network redundancy of transportation lines, devices and services
- Q-in-Q and VLAN trunks to the end-user
- Power autonomy with UPS at all active points for at least 12 hours
- Pay-as-you-grow solution
- Temperature hardened equipment to avoid the need for cooling systems
- Possibility to upgrade to wire-speed connectivity between AANs and aggregation network
- AAN nodes are less than 80km from the AGGN nodes
- Possibility to upgrade GPON to 10G PON and WDM PON
- Number of active users 130.000 in Slovenia and 70.000,00 in Croatia
- Two (2) redundant ISPCN (ISP Connection Node) – one in Slovenia and one in Croatia:
  - With aggregation network connecting ISPCN with AAN using different transportation networks available during network growth (leased and private)
  - Enabling all possible technological connection types: Ethernet, lambda or proprietary DWDM transport solution
- Optical network termination at the user premises

## 1.2 CUSTOMER REQUESTS IN NUMBERS

Beside general requests from customer side all proposed solutions must consider all the below listed information:

- Expected end-user (subscriber) number is beyond 200.000 split to **130.000** in Slovenia and **70.000,00** in Croatia (65:35 ratio), with possible end number 345.000
- Covered area on Slovenian part of network is 8.000 Km<sup>2</sup> and 5.320 Km<sup>2</sup> in Croatia:
  - 3.500 villages in Slovenia and
  - 1.100 in Croatia
- Customer is willing to use 90% of GPON access ports and at least 10% of XGS-PON 10G access ports. There should be:
  - At least **352 legacy GPON OLTs** (AAN)
  - At least **20 XGS-PON OLT** systems inside the network
- Customer must provide minimal 100 Mb/s downstream connectivity for following European Digital Agenda via legacy GPON and even more in case of XGS-PON to end-user
- In case of 1:64 GPON split ratio resulting in worst case traffic scenario end-user connection speed should be 39 Mb/s
- Each GPON OLT must be connected to two AGGN nodes and having both uplinks active

## 1.3 DETAILED TECHNICAL CUSTOMER REQUESTS

Customer has precisely defined basic network functionalities and capabilities, which must be supported in any possible solution. Any proposed technical solutions must include or support the following features, protocols and capabilities:

- Zero bandwidth impact during switch failover
- In-Service software upgrade (ISSU)
- IP service aware architecture to ensure optimal bandwidth efficiency and guaranteed instant channel changes
- Software that enables IMS integration and expands existing IP service aware features such as IGMP multicasting, VLAN tagging and stacking and security features
- Security and service segmentation features:
  - DHCP snooping/proxy
  - IP source guard/ Source verify
  - PPPoEiA and PPPoE profiles
  - MAC forced forwarding
  - IGMP V2 and V3
  - IGMP Snooping/Proxy
  - MVR to optimize IPTV delivery
  - IPV4 and IPV6 ACL
- Voice services with SIP or H.248 signalling
- Video services via IPTV
- Dynamic Bandwidth Allocation and HQOS
- 128 AES
- VLAN in VLAN (or Q-in-Q or VLAN trunking)
- IP-MPLS
- G.8032V2 (Ring support protocol)
- LAG protocol support on the access node in case of PTP connection

## 1.4 NETWORK MANAGEMENT/PROVISIONING REQUESTS

For easy maintenance, automatic provisioning, monitoring and overall system management each solution must support at least the next required network management functions:

- Any proposed solution must be SDN and NFV ready
- Open Flow Support must be included
- Native NETCONF/YANG must cover both provisioning and alarm/messaging
- In Service Software Upgrade (ISSU) is desired
- Management system should support well documented API interface
- Network and Service configuration, which is both On-line or Off-line
- Software upgrades
- Status request and command automation
- Statistics and performance data collection
- Alarm and event collection
- CRM or another platform should be offered for user management



## 2. INTRODUCTION INTO PROPOSED SOLUTION

### 2.1 INTRODUCTION

In the next lines some technical aspects of possible solution will be questioned and upon explaining all issues based on customer requests more solutions will be provided.

Previous chapters listed all customer-sourced requests. Beside all those listed and clearly stated in RFI documents, there are additional requests to be considered which are the base for the proposed solution(s).

#### 2.1.1 OVERALL AGGREGATION CAPACITY

As customer is looking for a network solution with maximum simplicity, scalability, security and manageability features, additional request for “non-blocking” capacity between AAN and CORE network has a strong impact to final solution from all points of view. The consequence of such request is that transport network without oversubscription (1:1 uplink / downlink ratio) should provide similar capacity as sum of all connections on the distribution network.

Considering the following numbers (of expected OLTs) and other facts:

- At least **352** legacy GPON OLTs (AAN)
- At least **20** XGS-PON OLT systems inside the network
- Numbers stated above are optimal numbers in best-case OLTs distribution scenario
- We consider at least **30% more** needed devices due to next reasons:
  - NON optimal geographic OLTs positioning
  - NON optimal user distribution over OLTs
  - Optical access network topology NOT known in this phase
- Expected final number of OLTs can rise to:
  - App. **460** of GPON OLTs and (rounded to **500** considering possible network growth)
  - App. **28** of XGS-PON OLTs (rounded to **35** considering possible network growth)

Keeping in mind the rounded final numbers:

- **500** legacy GPON OLTs systems possible in last stage
- **35** XGS-PON OLT systems possible in last stage

And with the additional request that double (2) UPLINKs must be provided from each OLT, we come to the first challenge:

- $500 \times 2 (10G) = 1.000,00 (10G)$  client ports must be provided in the AGGN layer aggregation
- $35 \times 2 (100G)$  or  $35 \times 4 (40G) = 70 (100G)$  or  $140 (40G)$  client ports must be additionally provided in the AGGN layer aggregation
- Overall **GPON capacity** is  $500 \times 2 \times 10G = 10 + 5 \text{ Tb/s} = 15 \text{ Tb/s}$  (10.000 Gb/s DOWNLINK and 5.000 Gb/s UPLINK)
- Overall **XGS-PON capacity** is  $35 \times 2 \times 100 = 7 + 7 \text{ Tb/s} = 14 \text{ Tb/s}$  (7.000 Gb/s DOWNLINK and 7.000 Gb/s UPLINK in case of symmetrical XGS-PON)
- Overall transport network system capacity being  $15 + 14 \text{ Tb/s} = 29 \text{ Tb/s}$
- Summarized number of client ports (1.000 X 10G and 70 X 100G) requires theoretically **170 100G** uplink ports if following 100% non-blocking request!

- We must also consider some additional ports in case any of them are used for redundancy reasons between devices

Question emerging from calculation above is how transport network capacity should and must be planned. Upper calculations highlights two major challenges:

- Routing/switching capacity of AGGN devices
- UPLINK and DOWNLINK density of Ethernet ports on AGGN devices
- Ports for other functionalities (redundancy, management)

## 2.1.2 OVERALL UPLINK CAPACITY

Based on the calculation in chapter 3.1.1 the following challenges arise from upper results:

- Proper calculation of required number of transportation channels between AGGN nodes and ISPCN nodes (UPLINK channels)
- Total capacity toward core network

## 2.1.3 INTERFACE TYPE CHOICE

Additional problem while proposing adequate solution is the choice of technologies used for UPLINK connections from AGGN devices. There are few possible types each having different technical characteristics:

- Optical “grey” ethernet interfaces (40 and 100G)
  - QSFP-40GBASE-ER4 functions as four lane CWDM on wavelengths 1270nm-1330nm with typical power-budget 16.5 dB
  - 100GBASE-ER4 functions as four lane WDM system – 1296nm, 1300nm, 1305nm, 1309nm with typical power-budget of 17.5 dB per wavelength
- Optical coloured DWDM Ethernet interfaces (40 and 100G)
  - No DWDM transceivers available for 40G standard
  - 100GBASE-CWDM4 available with dual speed 100G / 40G with max. distance 2km
  - DWDM QSFP28 100Gb/s functions on 2 wavelengths using 50 GHz DWDM grid, where PAM4 modulation format enables 56 Gb/s on a single wavelength. Typical transmit power is -10 dBm, and receive sensitivity is -2 dBm. This brings need for additional amplifier on both sides. Typically such 40-channel DWDM systems are used as transport on max.distance of 80km.
- Long Haul CFP interfaces using coherent DWDM technology, which has less limitations compared to solutions above and require properly designed active DWDM system for long-haul transmission. This solution has no technical limitation for the possible maximum optical fibre distances used in this project.

Choice of any of them is not simple due to next reasons:

- As network topology is not known, distances are not known
- Interfaces listed above:
  - Are of different hardware types therefore requiring different mother devices (router, switches, DWDM devices)
  - Have different power budget, which indicates different possible maximum distances (10, 40, 80 or even more than 80 km)

- Their actual price range is wide (price ratio is up to 1:10 or even more in case of long haul coherent solution), which gives a major impact on the overall solution
- None of them can be proposed to any length before each transmission line is measured according to all necessary standards
- Any proposed solution is based on assumption that transmission line (optical fibers used for connecting the locations) is in excellent or good state (with attenuation of optical fibers between **0.19** and **0.25 dB/Km**). If final loss values on the optical fiber links are worse than expected due to different reasons (additional or bad splices and patches, dirty connectors, etc) or due to specific situations (optical fiber links are passing via or next to electrical-distribution cables) all presumed calculations can fail and result in several consequences as follows:
  - Additional hardware requirement like optical amplifiers on existing locations at each end of the optical fiber link as well as a potential need for additional active sites on the optical fiber link between end locations, which adds to operating expenses
  - In worst case scenario there will be a need for technology replacement in case that total loss or distance will become limiting factor for chosen DWDM solution (more affordable DWDM solutions have certain distance limitation explained at the beginning of this section)

## 2.1.4 CORE NETWORK AGGREGATION

All of the above mentioned issues on the very end have a direct impact to core network design. Core network must:

- Provide enough connection capacities to redundantly aggregate network traffic/data from all AGGN nodes
- Provide enough scalability and must be able to grow as the number of users grow
- Have enough processing capacities to handle all the possible traffic (incoming, outgoing)
- Have enough connection capacities for:
  - Redundant connections in case of redundant core nodes (Slovenia, Croatia)
  - Connecting ISP and content providers (even redundantly)
  - Connection to its management servers located in datacentres locally in the core locations
  - Connection to service datacentre in case of L3 network setup
- Core network must also support all requested functionalities, protocols and capabilities listed in customer requests section (section 2.).
- Core network must be ready for all now known future needs, applications and standards
- Unpredicted network growth in case of faster user/traffic growth then predicted shouldn't and must not have any impact on network core from any technical aspect
- Pay as you grow Feature/Functional expansion
  - BNG to be distributed across the AGGN/SD nodes for scaling and turn/on/off on a per sub basis
  - L3 features/functionality on a per subscriber basis

## 2.1.5 PREDICTED SUBSCRIBERS NUMBER

Predicted and expected final subscriber number is treated as real as it's based on number of official listed households in so called "grey-zones". However there is one not considered factor which was not mentioned or considered so far:

Predicted and expected final subscriber number is treated as real as it's based on number of official listed households in so called "grey-zones". However there are additional factors, which were not mentioned or considered so far:

- Beside regular users more and more Internet connections are being used for M2M communication
- All areas which will be covered with optical network connectivity as part of RUNE project will represent a primary option for all future communication needs as there is lack of other infrastructure
- Keeping in mind also all IOT and involved municipality needs (including municipality applications) a MAC address table is expected to grow very high even in case of traffic tunnelling (Q-in-Q or VLAN tagging)
- Dealing with high number MAC address tables requires first a type of telecom grade network equipment having enough processing power and MAC address capacities as well as support for all L2/L3 functions used for minimizing broadcast domains

## 2.1.6 TRANSPORTATION LEVEL SERVICES

One of customer requests is a need for higher level services (IP-MPLS or similar), which must be possible throughout the network. IP-MPLS solution should service as protocol that enables all other traffic to pass through the network as transparent as possible. IP-MPLS service is a foundation of Open Access Networks enabling different ISP and content providers to deliver their traffic from network core to network edge.

Customer must be aware that network will have to be able to provide much higher performances and functionalities when offering specific network services:

- Connectivity of mobile operators from AGGN nodes to core according to MEF standards
- Connectivity of ISP or content providers on AGGN node levels when no other connection possible
- High Speed Ethernet connectivity across network from one edge to another as service
- IP MPLS grade QoS for future critical infrastructure needs

## 2.1.7 AGGREGATION AND CORE NETWORK FUNCTIONS

The **key features** needed at the aggregation and core transport layer include:

- High-density Ethernet Links Aggregation from access layer
- Non-blocking and low latency forwarding of the transit traffic to core segment
- Perform EVC stitching to provide continuous End-to-End layer 2 EVC
- Perform S-VLAN normalization
- OAM and network resiliency features
- Inline timing and synchronization support for voice and TDM applications
- Support for versatile Layer 2 Carrier Ethernet and Layer 3 Services over MPLS
  - Performing of Layer 2 EVC to Layer 3 Service stitching

The following protocols must be supported on any routing device in AGGN and ISPCN layer:

- ISIS, OSPF/OSPFv3, BGP and BGP RR, RSVP, LDP, Segment routing
- IP/MPLS (L3) services
  - EVPN, VPLS ,L3VPN, PWE3,
  - P2MP LSP (mLDP and RSVP EVPN-MPLS),

- L2 services
  - MPLS-over-GRE, VXLAN, GRE
- Bridge Port Extension (802.1BR)
- High Availability
  - Redundant Routing engine, NSR, ISSU, GRES, BFD
- Metro Ethernet
  - Support for OAM features
  - Must be MEF CE 2.0 certified on designed networks speeds (10G and 100G)
- Precision time protocols (PTP)
  - IEEE 1588 and SyncE
- PCEs (Path Computation Elements)

## 2.1.8 ACCESS LAYER SERVICES

The access layer consists of the access nodes, which are typically deployed in vicinity of the customer devices and enterprise customer premises. Therefore protocols for user access and connectivity to upstream aggregation routers are needed. The key requirements for the access layer are:

- Provide connectivity for customer equipment on the physical port—user network interface (UNI)
- One UNI connects one subscriber device, which is Layer 3 CPE
- Enable Ethernet Virtual Connection (EVC) towards the remote UNI and establish OAM control plane on a per EVC basis
- Bundle customer CVLAN and map it to EVC connection
- Multiplex multiple EVCs on a single UNI
- Apply network service attributes
- Properly designed performance and bandwidth to meet growing service needs
- Allow for Residential and business services
  - CE services for Business with OAM and HQOS to deliver Business Class SLA and Carrier Ethernet (MEF) conform services
  - L2/L3 residential CPE to deliver residential services
- Integrated remote diagnostics to reduce troubleshooting times and on-site visits
  - Integrated Videocontent Analyzer to analyse MPEG over IP/Multicast
  - Tcpcdump
  - Integrated Wireshark network analysis for realtime debug

Software features must be supported to deliver an enhanced quality of experience (QoE)—class of service, network resiliency, and OAM.

## 2.2 PROPOSED SOLUTION

There is no simple solution for the requested network design. There are several factors, which have minor or major impact on final network design and there are simply too many variables, which cannot be put into a “non-risky” frame for taking them as granted base for further calculations.

In the following sections the document is providing all technical, economical, geographical, administrative and other factors having an influence over final choice.

Following are customer’s requests.

## 2.2.1 SYSTEM CAPACITY

In previous chapters calculations have been made if the system should be supporting “non-blocking” policy and adequate transport capacities. Note: upgradeable to non-blocking at full capacity.

The Figure 1 below is providing typical design for telecommunication networks, which takes into account the uplink capacity of 400Gbps.

The AAN nodes shall support redundant connectivity to the SD/AGGN node, P2P uplink via LAG and also G.8032v2 ring support for areas with lower densities to optimize utilization of uplink fibers.

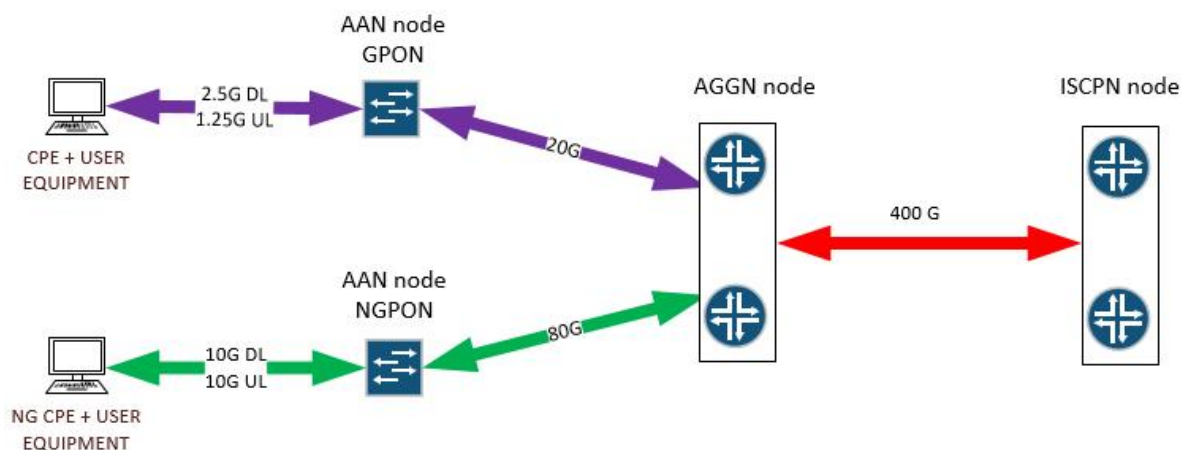

Figure 1: Network capacity

## 2.2.2 CAPACITY PLANNING

Capacity planning was done strictly mathematically summarizing all distribution nodes (OLTs) capacity. It is technologically optimal to connect OLTs with “wire-speed” to AGGN on limited distance due to:

- Maturity of 10G (SFP+) technology
- Marginal price for best technological solution (reach of 100 Km) due to mass economy of this type of interface
- Possible 100% line utilization on AAN access interfaces

There is no same logic for the communication between AGGN and ISPCN core network, as distances are longer and multiplexing data traffic into one or more high speed channels (wavelengths) is implemented in order to use as few optical fibres as possible. Amount of traffic is different at this layer due to several reasons:

- Limited broadcast and multicast domains
- Multicast (IPTV traffic) not replicated over several users, but using one traffic stream toward multiple end users instead between ISPCN and AGGN devices

Optimization in this segment is of critical importance for bringing network design to a real-life scenario.

## 2.2.3 TRANSPORT NETWORK

Under normal circumstances each network is designed in the way that mature, widely used and economically available technologies and capacities are used. If transportation system should be planned for expected level, we come to the next technological realities and limitations:

- If **10G** interfaces are primary choice for aggregating all OLTs to AGGN (client aggregation), only logical choice for uplink are next level type interfaces: **40G** and **100G**.
- Another advantage for 10G interfaces is its long-haul capacities reaching 100 km as well as I-Temp support today.
- **40G** technology is intended for datacentre server aggregation and this is the reason it's not widely used for geographical long-haul connections: its maximal reach in today's technology is **40Km and no I-Temp optics are currently available**, what makes it not usable for our design
- Decreasing number of (active) AGGN nodes due to network optimization for lowering operating expenses on the other hand adds to less but high density network nodes requiring higher uplink capacities
- It becomes clear that the only possible solution for high-speed connection from AGGN nodes to core network is **100G** technology

100G implementation using cheaper 100G technology today has its advantages and drawbacks. The advantages are:

- It's a »natural« way of increasing 10G capabilities with substantial capacity rise
- 100G coming in QSFP28 form have almost the same distance capabilities as 10G modules
- QSFP28 modules are available already today and also »acceptable« from price/performance point of view for certain applications

The disadvantages of cheaper 100G technology are:

- Cheaper 100G technology implementations does support long distances but much more prone to transmission lines quality then 10G interfaces
- Cheaper 100G technology effective range decreases due to higher sensitivity to transmission lines quality
- If a network must extend beyond 80 Km, we encounter a huge price/performance change showing in significantly increased price of such solutions, which support longer distance 100G implementations
- In case of using commercially available and affordable short-range DWDM systems (up to 80 Km), we must face other technological limitations which result in need for additional active equipment and higher level of planning attention of design possible only in case of having real information about optical line
- There is also a higher quality long haul (long distance) 100G solutions available, which take into account coherent 100G technology, where price is the main disadvantage.

## 2.2.4 NETWORK TOPOLOGY

Lack of predefined network topology is a problem when preparing this proposal. Possible locations of network nodes are proposed (LJ, PO, CE, KR, NM, MB, Opatija, Istra (W) and Istra-Rijeka (E) – precise location can change. There will be a need to lease transmission lines between AGGNs and ISPCNs from well-known operators (Telekom, DARS, Stelkom), however transmission lines parameters of any operator are not known in advance.

Figure 2 below is providing the approximate location for AGGNs and ISPCNs and indicates approximate locations where optical fibers will be leased. The links in the figure are physical links between devices and/or locations.

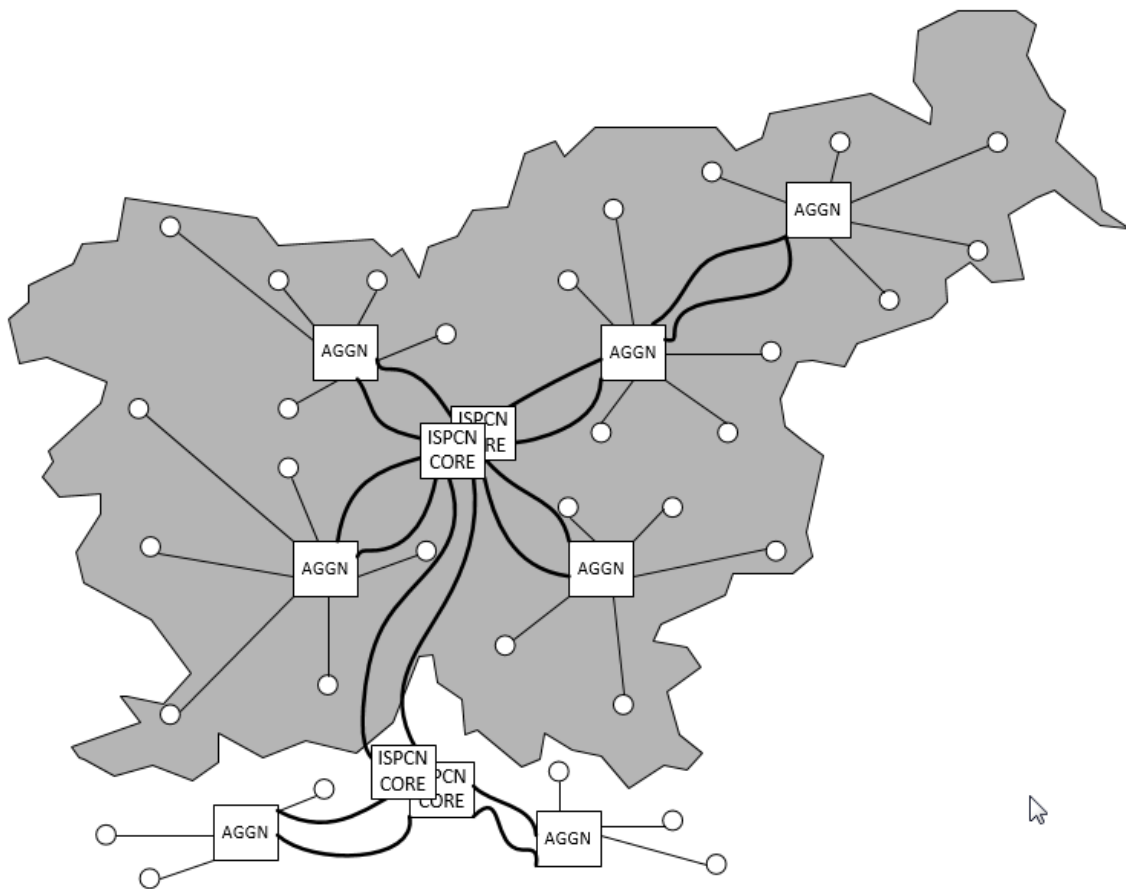

Figure 2: Network topology - AGGN and ISPCN nodes

Proposed solution is based on most logical assumptions and considering all necessary precautions when dealing with optical transmission lines lengths and quality.

Another assumption is that newly deployed optical fiber cables will meet the highest standards for technical specifications allowing us to use long-haul »grey« or DWDM optics in »dark-fibre« scenarios. Figure 3 is very similar to Figure 2, but it is focusing on the logical connectivity between devices and/or locations.



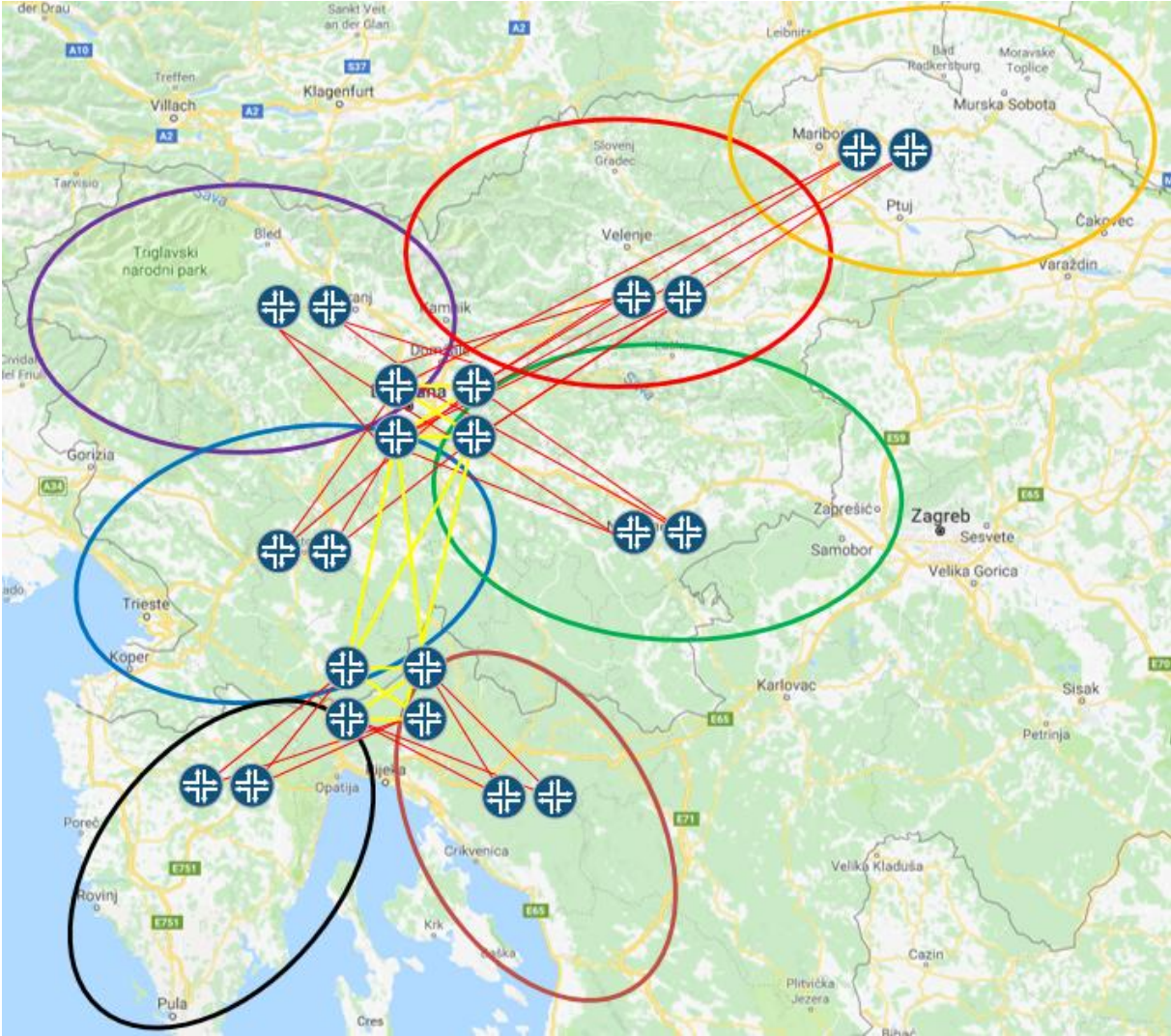

Figure 3: Region RUNE-SI and RUNE-ADRIA

## 2.2.5 REDUNDANCY OF THE PROPOSED SYSTEM

There are different requests for redundancy, therefore solution should achieve redundancy with the following elements:

- **Path** redundancy
  - Connection between all ISPCN nodes is done via two geographically independent fibre connections
  - Connection between ISPCN and each AGGN node is done via two geographically independent fibre connections
  - Connection between AGGN and each AAN node is done via two geographically independent fibre connections
  - There is no path redundancy between AAN node and end-user CPE equipment
- **Device** redundancy
  - There are redundant routing devices in ISPCN node
  - There are redundant routing devices in AGGN node
  - There is no redundant routing device (switch) in AAN node
- **Routing engine** redundancy
  - Routing device in ISPCN node has redundant routing engine with unified ISSU
  - Routing device in AGGN node has redundant routing engine with unified ISSU
  - There is no redundant routing engine in AAN node
- **Active device power** redundancy
  - Routing device in ISPCN node has redundant hot-swappable power supply
  - Routing device in AGGN node has redundant hot-swappable power supply
  - Routing device (switch) in AAN node has redundant power feeds
- **Active device cooling** redundancy
  - Routing devices in ISPCN and AGGN node have hot-swappable fans
  - Routing device (switch) in AAN node has resilient multi-fan design for maintaining the system temperature with one fan failure
- **UPS/power** redundancy
  - There are redundant power supply options in ISPCN and AGGN nodes
- **Optical transmitter** redundancy
- **Datacentre** redundancy
  - Datacentre services needs to be redundant for every country. Datacentre infrastructure is proposed in both datacentres in Slovenia and in Croatia.

Network resiliency is requested in any network layer.

- ITU G.8032 ERPS, RSTP and 802.3AD/802.1AX protocols are protocols between AAN and AGGR nodes
- ITU G.8032 ERPS, RSTP and 802.3AD/802.1AX protocols are protocols between AGGN and ISPCN nodes
- Service protection is requested within IP-MPLS network, two EVC or two LSPs are requested among two UNI interfaces
- MPLS FRR is requested within IP-MPLS network

Figure 4 is providing the complete view of the topology while showing different layers of operation and different levels of connection redundancy.

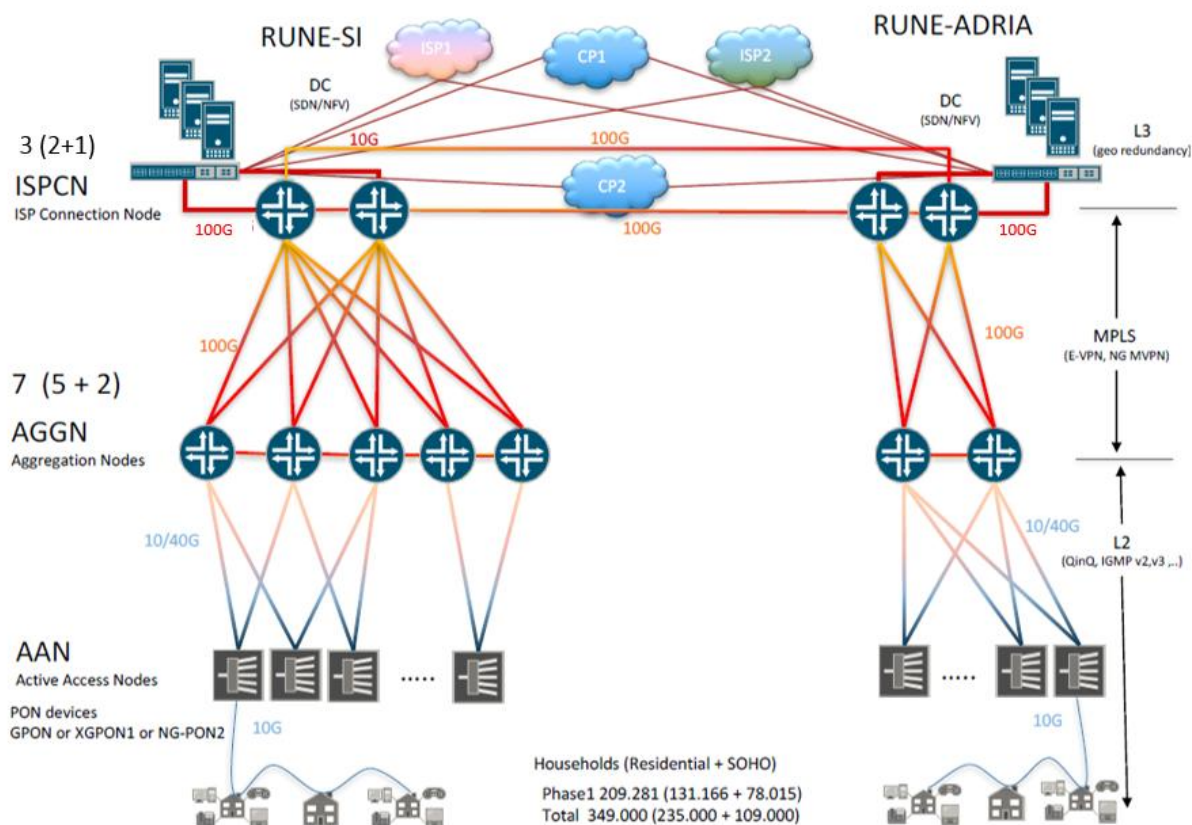

Figure 4: Basic Network Topology

## 2.2.6 ISPCN – CORE NODE

Core Node or ISP Connection Node (ISPCN) will provide interconnection between all aggregation nodes (AGGN) and provide peering / upstream node where all IPS and Content providers will be connected to. ISPCN will provide interconnection between both networks as well. ISPCN will provide also Datacentre for NMS and other services. ISPCN will provide interconnection between RUNE-SI and RUNE-ADRIA networks.

There are four Core Node locations – two in Slovenia (ISPCN RUNE-SI WEST and ISPCN RUNE-SI EAST) and two in Croatia (ISPCN RUNE-ADRIA WEST and ISPCN RUNE-ADRIA EAST), each with redundant connection to other ISPCN. Every ISPCN node offers datacentre with high-availability architecture.

ISPCN core node needs to be built with a minimum of two separate Core Routing Devices (CD) to provide High Availability, each with at least 24 of 100GE and 12 of 10/40GE ports devices for Datacentre, where all NMS and/or OSS/BSS should be installed. Four Sattelite Devices (SD) with multiple 100GE connections to CD are needed. Each SD should have at least 48 of 10GE access ports.

Two SD devices with access ports will be needed for connecting Datacentre infrastructure to core network. Another two SD devices will be needed for ISP and content providers to connect to core network. Multiple 1 GE, 10 GE, 40 GE and 100 GE options will be available for connection.

All devices in ISPCN must operate as one logical unit with single management.

Datacentre will provide also other requested services, like DNS, DHCP, BNG, PPPoE, IPoE, L2TP, firewall, RADIUS, SDN, management and other necessary services. Next Generation Firewalls must be placed in the ISPCN node to protect those services. Security polices and firewall rules with advanced Next Generation features (IPS, application awareness, anti-malware, DOS protection, ...) should be put in

place to protect servers hosting services in the ISPCN node and prevent the services from being compromised. Firewalls must have redundant power supply, performance of at least 3 Gbps on Next Generation features (IPS, application awareness, anti-malware, DOS protection, ...) and must be deployed in a high availability solution.

High Availability from AAN to ISPCN will be provided by L3 routing protocols, based on IGP protocols ISIS and OSPF with MPLS services signalled via BGP. Basic MPLS services will be E-VPN and NG-MVPN. For management and some other specific services will be used L3VPN as well.

IPv4 and IPv6 must be supported through complete network, as well for all Wholesale services. Core and Aggregation network must also support PTP (Precision Time Protocol).

Figure 5 is showing the architecture of the ISPCN node including connectivity between different devices involved into the solution.

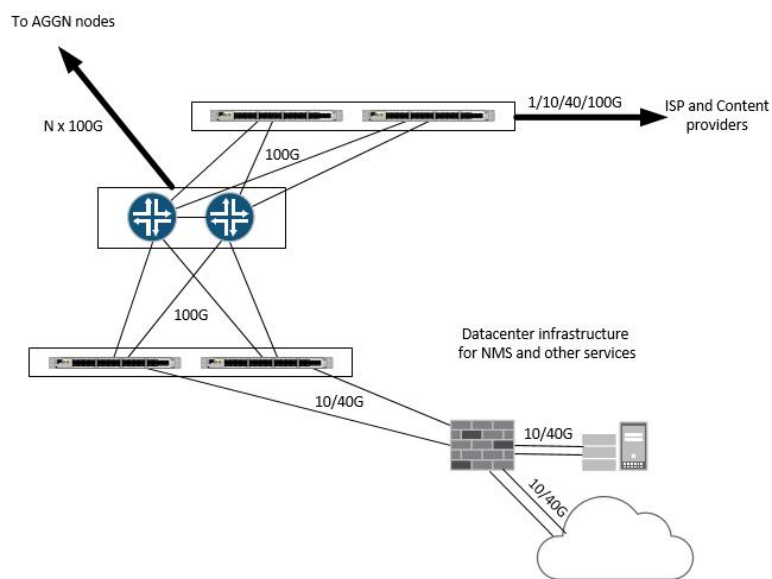

Figure 5: ISPCN node

Each routing device must have redundant routing engine with unified ISSU and redundant power supply and be SDN ready. Routing engine of each routing device should be able to forward at least 4.8 Tbps of traffic passing through the device.

Figure 6 provides the physical and logical view of interconnection between ISPCN nodes.

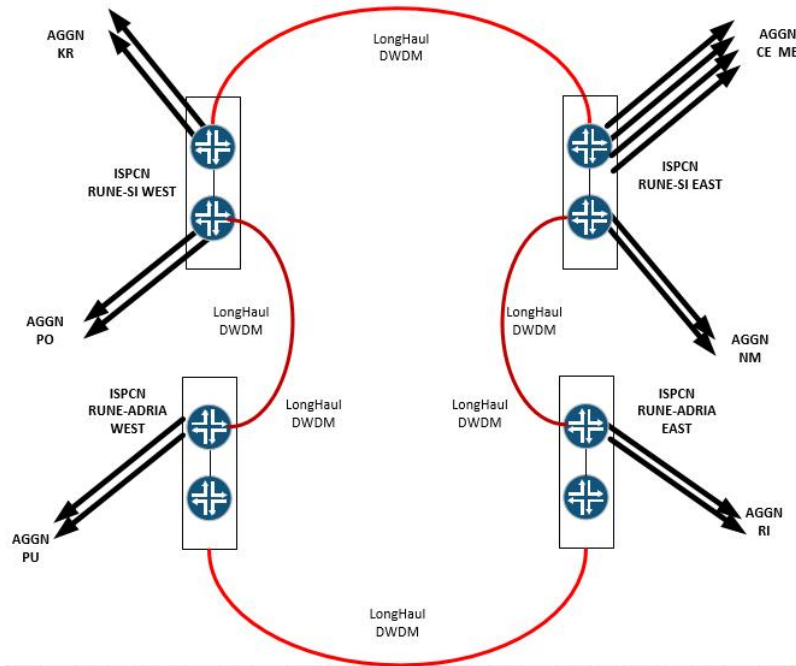

Figure 6: ISPCN node interconnect

2.2.6.1 ISPCN NODE RUNE-SI WEST - TABLE

	EQUIPMENT/SERVICE	Quantity
1.	<b>CORE NETWORK EQUIPMENT:</b> Core network EDGE routers 2 X 12 100G QSFP28 ports 2 X 6 40G QSFP ports 2 X Routing Engine, 2 X Power Supply <b>4.8 Tb/s capacity</b> (SUM: 24 X 100G, 12 X 40G)	2
2.	<b>CORE NETWORK EQUIPMENT:</b> Core network EDGE extension and aggregation switches (ISP/CONTENT PROVIDER and DATACENTRE SIDE) 48 X 10G SFP+ ports 4 X 100G QSFP28 ports 1 X Switching Engine, 2 X Power Supply	4
3.	<b>CORE NETWORK MANAGEMENT EQUIPMENT:</b> Core network management switches (MANAGEMENT SIDE) 48 X 1G PoE 4 X 10G SFP+ ports 2 X Power Supply Stack support	2
4.	<b>CORE NETWORK EQUIPMENT:</b> <b>CORE NETWORK PROTECTION</b> Core network security protection firewalls	1

	<p>12 X 1G UTP                  4 X 10G SFP+ ports                  1 X Management port                  3 Gb/s capacity                  NGFW features                  2 X PS</p>	
5.	<p><b>CORE NETWORK EQUIPMENT:                  MANAGEMENT AGGREGATION                  PROTECTION</b>                  Core network security protection                  firewalls (BORDER DEVICES)                  6 X 1G UTP                  1 X Management port                  2 Gb/s SSL VPN capacity                  NGFW features</p>	1
6.	<p><b>CORE NETWORK MANAGEMENT                  EQUIPMENT:</b>                  CORE network management VPN                  routers (MANAGEMENT SIDE)                  8 X SFP GE ports                  8 X 10/100/1000 RJ-45 ports                  2 X Power Supply</p>	2
7.	<p><b>CORE NETWORK EQUIPMENT:                  CORE NETWORK MANAGEMENT                  SERVERS</b>                  Management servers                  2 X CPU                  2 X PS                  2 X (2 X 10G)                  60 TByte RAID 5 storage                  All Windows licenses included                  All VMware licenses included</p>	1
8.	<p><b>CORE NETWORK EQUIPMENT:                  NTP SERVERS</b>                  NTP GPS based servers</p>	1
9.	<p><b>CORE NETWORK MANAGEMENT                  APPLICATION:                  SOFTWARE SUITE FOR MANAGING ALL                  AGGN AND CORE DEVICES</b>                  One-point provisioning for all L2/L3                  network devices providing fully                  automated network management</p>	1
10.	<p><b>CORE ACCESORIES:                  CORE NETWORK ACCESSORIES, CABLES                  AND OTHER CONSUMABLES:</b>                  UTP cable sets                  AOC/DAC cable sets                  Optical transceivers included                  230V UPS with at least 12h autonomy, 3-                  phase, 15 KVA, 46 RU height</p>	1

	SUM of ISPCN power: 10 KW Active equipment ISPCN: 38 RU height	
--	---	--

Table 1: ISPCN NODE RUNE-SI WEST

2.2.6.2 ISPCN NODE RUNE-SI EAST - TABLE

	EQUIPMENT/SERVICE	Quantity
1.	<b>CORE NETWORK EQUIPMENT:</b> Core network EDGE routers 2 X 12 100G QSFP28 ports 2 X 6 40G QSFP ports 2 X Routing Engine, 2 X Power Supply <b>4.8 Tb/s capacity</b> (SUM: 24 X 100G, 12 X 40G)	2
2.	<b>CORE NETWORK EQUIPMENT:</b> Core network EDGE extension and aggregation switches (ISP/CONTENT PROVIDER and DATACENTRE SIDE) 48 X 10G SFP+ ports 4 X 100G QSFP28 ports 1 X Switching Engine, 2 X Power Supply	4
3.	<b>CORE NETWORK MANAGEMENT EQUIPMENT:</b> Core network management switches (MANAGEMENT SIDE) 48 X 1G PoE 4 X 10G SFP+ ports 2 X Power Supply Stack support	2
4.	<b>CORE NETWORK EQUIPMENT: CORE NETWORK PROTECTION</b> Core network security protection firewalls 12 X 1G UTP 4 X 10G SFP+ ports 1 X Management port 3 Gb/s capacity NGFW features 2 X PS	1
5.	<b>CORE NETWORK EQUIPMENT: MANAGEMENT AGGREGATION PROTECTION</b> Core network security protection firewalls (BORDER DEVICES) 6 X 1G UTP 1 X Management port 2 Gb/s SSL VPN capacity NGFW features	1
6.	<b>CORE NETWORK MANAGEMENT EQUIPMENT:</b>	2

	CORE network management VPN routers (MANAGEMENT SIDE) 8 X SFP GE ports 8 X 10/100/1000 RJ-45 ports 2 X Power Supply	
7.	<b>CORE NETWORK EQUIPMENT: CORE NETWORK MANAGEMENT SERVERS</b> Management servers 2 X CPU 2 X PS 2 X (2 X 10G) 60 TByte RAID 5 storage All Windows licenses included All VMware licenses included	1
8.	<b>CORE NETWORK EQUIPMENT: NTP SERVERS</b> NTP GPS based servers	1
9.	<b>CORE ACCESORIES: CORE NETWORK ACCESSORIES, CABLES AND OTHER CONSUMABLES:</b> UTP cable sets AOC/DAC cable sets Optical transceivers included 230V UPS with at least 12h autonomy 3-phase, 15 KVA, 46 RU height  SUM of ISPCN power: 10 KW Active equipment ISPCN: 38 RU height	1

Table 2: ISPCN NODE RUNE-SI EAST

2.2.6.3 ISPCN NODE RUNE-ADRIA WEST - TABLE

	EQUIPMENT/SERVICE	Quantity
1.	<b>CORE NETWORK EQUIPMENT:</b> Core network EDGE routers 2 X 12 100G QSFP28 ports 2 X 6 40G QSFP ports 2 X Routing Engine, 2 X Power Supply <b>4.8 Tb/s capacity</b> (SUM: 24 X 100G, 12 X 40G)	2
2.	<b>CORE NETWORK EQUIPMENT:</b> Core network EDGE extension and aggregation switches (ISP/CONTENT PROVIDER and DATACENTRE SIDE) 48 X 10G SFP+ ports 4 X 100G QSFP28 ports 1 X Switching Engine, 2 X Power Supply	4
3.	<b>CORE NETWORK MANAGEMENT EQUIPMENT:</b>	2



RUNE – CONFIDENTIAL – HLD AGGREGATION AND CORE

	Core network management switches (MANAGEMENT SIDE) 48 X 1G PoE 4 X 10G SFP+ ports 2 X Power Supply Stack support	
4.	<b>CORE NETWORK EQUIPMENT: CORE NETWORK PROTECTION</b> Core network security protection firewalls 12 X 1G UTP 4 X 10G SFP+ ports 1 X Management port 3 Gb/s capacity NGFW features 2 X PS	1
5.	<b>CORE NETWORK EQUIPMENT: MANAGEMENT AGGREGATION PROTECTION</b> Core network security protection firewalls (BORDER DEVICES) 6 X 1G UTP 1 X Management port 2 Gb/s SSL VPN capacity NGFW features	1
6.	<b>CORE NETWORK MANAGEMENT EQUIPMENT:</b> CORE network management VPN routers (MANAGEMENT SIDE) 8 X SFP GE ports 8 X 10/100/1000 RJ-45 ports 2 X Power Supply	2
7.	<b>CORE NETWORK EQUIPMENT: CORE NETWORK MANAGEMENT SERVERS</b> Management servers 2 X CPU 2 X PS 2 X (2 X 10G) 60 TByte RAID 5 storage All Windows licenses included All VMware licenses included	1
8.	<b>CORE NETWORK EQUIPMENT: NTP SERVERS</b> NTP GPS based servers	1
9.	<b>CORE ACCESORIES: CORE NETWORK ACCESSORIES, CABLES AND OTHER CONSUMABLES:</b> UTP cable sets AOC/DAC cable sets Optical transceivers included	1

	230V UPS with at least 12h autonomy, 3-phase, 15 KVA, 46 RU height  SUM of ISPCN power: 10 KW Active equipment ISPCN: 40 RU height	
--	---	--

Table 3: ISPCN NODE RUNE-ADRIA WEST

2.2.6.4 ISPCN NODE RUNE-ADRIA EAST - TABLE

	EQUIPMENT/SERVICE	Quantity
1.	<b>CORE NETWORK EQUIPMENT:</b> Core network EDGE routers 2 X 12 100G QSFP28 ports 2 X 6 40G QSFP ports 2 X Routing Engine, 2 X Power Supply <b>4.8 Tb/s capacity</b> (SUM: 24 X 100G, 12 X 40G)	2
2.	<b>CORE NETWORK EQUIPMENT:</b> Core network EDGE extension and aggregation switches (ISP/CONTENT PROVIDER and DATACENTRE SIDE) 48 X 10G SFP+ ports 4 X 100G QSFP28 ports 1 X Switching Engine, 2 X Power Supply	4
3.	<b>CORE NETWORK MANAGEMENT EQUIPMENT:</b> Core network management switches (MANAGEMENT SIDE) 48 X 1G PoE 4 X 10G SFP+ ports 2 X Power Supply Stack support	2
4.	<b>CORE NETWORK EQUIPMENT: CORE NETWORK PROTECTION</b> Core network security protection firewalls 12 X 1G UTP 4 X 10G SFP+ ports 1 X Management port 3 Gb/s capacity NGFW features 2 X PS	1
5.	<b>CORE NETWORK EQUIPMENT: MANAGEMENT AGGREGATION PROTECTION</b> Core network security protection firewalls (BORDER DEVICES) 6 X 1G UTP 1 X Management port 2 Gb/s SSL VPN capacity NGFW features	1

6.	<p><b>CORE NETWORK EQUIPMENT: CORE NETWORK PROTECTION AND MANAGEMENT AGGREGATION</b></p> <p>Core network security protection firewalls (BORDER DEVICES) 4 X 1G UTP 4 X 10G SFP+ ports 1 X Management port 1.5 Gb/s capacity SSL VPN 2 X PS</p>	1
7.	<p><b>CORE NETWORK MANAGEMENT EQUIPMENT:</b></p> <p>CORE network management VPN routers (MANAGEMENT SIDE) 8 X SFP GE ports 8 X 10/100/1000 RJ-45 ports 2 X Power Supply</p>	2
8.	<p><b>CORE NETWORK EQUIPMENT: CORE NETWORK MANAGEMENT SERVERS</b></p> <p>Management servers 2 X CPU 2 X PS 2 X (2 X 10G) 60 TByte RAID 5 storage All Windows licenses included All VMware licenses included</p>	1
9.	<p><b>CORE NETWORK EQUIPMENT: NTP SERVERS</b></p> <p>NTP GPS based servers</p>	1
10.	<p><b>CORE ACCESSORIES: CORE NETWORK ACCESSORIES, CABLES AND OTHER CONSUMABLES:</b></p> <p>UTP cable sets AOC/DAC cable sets Optical transceivers included 230V UPS with at least 12h autonomy, 3- phase, 15 KVA, 46 RU height</p> <p>SUM of ISPCN power: 10 KW Active equipment ISPCN: 40 RU height</p>	1

Table 4: ISPCN NODE RUNE-ADRIA EAST

## 2.2.7 AGGN NODE

For RUNE-SI we split Slovenia to 5 regions, which can cover connections to all AANs in Slovenia. For RUNE-ADRIA we split part of Croatia to 2 regions, which can cover connections to all AANs in Croatia.

To achieve the appropriate aggregation of AANs we plan to use routers with 802.1BR within each Aggregation Node (AGGN). Each AGGN node must be built with two Aggregation Devices (AD) in the

center of region and four to five Satellite Devices (SD) (four within Slovenian AGGNs and five within Croatian AGGNs) within the same AGGN location. AD and SD are connected with multiple 100Gbps connections. So, each SD needs to have minimum of two upstream 100GE interface which will be connected to two ADs in the central site of region. All upstream links on SD must be active. Each SD should have at least 48x 10GE access ports, per AGGN node there should be at least 160x 10GE access ports (RUNE-SI) and at least 220x 10GE access ports (RUNE-ADRIA). All devices in AGGN must be seen as one logical unit with single management. AGGN devices need to have redundant routing engine – redundant control plane with unified ISSU and redundant power supply and be SDN ready.

All AGGN devices need to support IGP protocols (ISIS and OSPF) and all necessary MPLS services: L3VPN, VPLS, E-VPN and NG-MVPNs and all L2 and OAM services.

Due to the lack of rack space a high density of 100GE ports is required, preferable at least 12x 100GE ports per slot.

Independent management connection to every device within AGGN node is planned in-band via switches and mobile routers with backup 2G/3G/4G connections. Secure out-of-the-band connection via VPN to the management system is strictly required.

Figure 7 shows the connectivity between AGG and SD devices, where each SD device is connected to at least two different AGG devices for the purpose of redundancy.

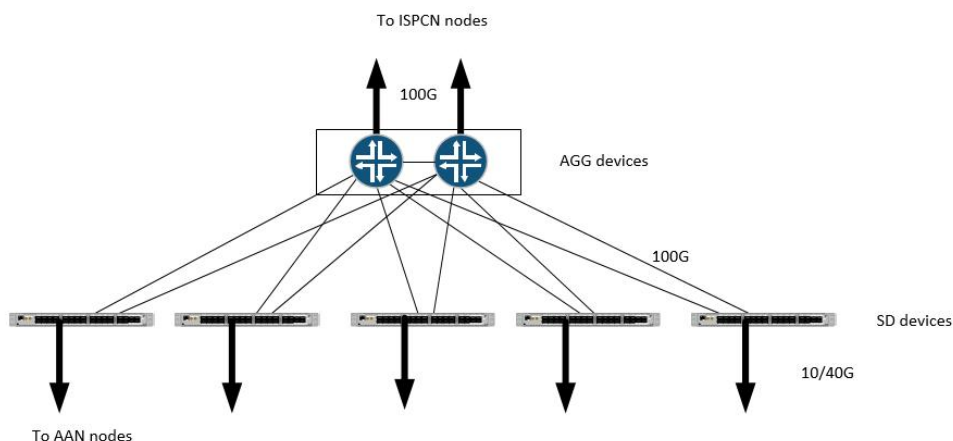

Figure 7: AGGN node interconnect (AD and SD devices)

Aggregation node capacity (routing, switching) must be scalable, node capacity upgrade (adding new devices, ports, slots or optical connections into existing node) should be possible without need to interrupt services for existing connections.

Aggregation node capacity should be at minimum 4,8 Tb/s as capacity should not be undersized due to the number of ports to the AAN nodes. Aggregation node needs to be able to handle all traffic that arrives to the node. Undersized design of the aggregation nodes could impact the performance and reliability.

Figure 8 is summarizing the throughput of the AGGN nodes.

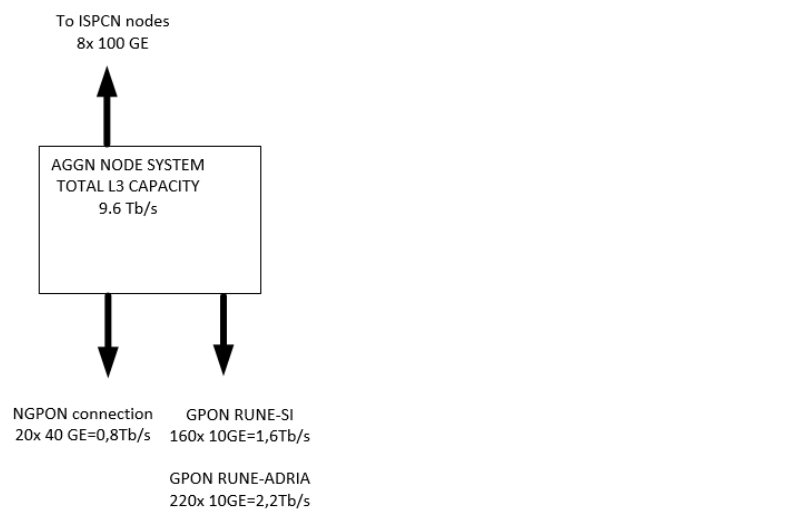

Figure 8: AGGN node throughput

NOTE: proposed network solution is dealing with the predicted, really needed or potentially needed network connections in the first phase as well as total lifetime of project. While there are all possible reasons in order to optimize final network design from connections point of view and to design the uplink capabilities to final numbers, this same logic is not applicable to network AGGN node and core network equipment (L2/L3 devices). AGGN nodes and core network devices must be well chosen and future proof from very beginning. Wrong choice of equipment at this stage means a need of total replacement of equipment from:

- CAPACITY of handling all network traffic point of view
- REDUNDANCY point of view
- CONNECTIVITY point of view

2.2.7.1 AGGN NODE POSTOJNA – TABLE

	EQUIPMENT/SERVICE	Quantity
1.	<b>AGGN NODE NETWORK EQUIPMENT:</b> AGGN network EDGE routers 1 X 12 100G QSFP28 ports 2 X 6 40G QSFP ports 2 X Routing Engine, 2 X Power Supply <b>4.8 Tb/s capacity</b> (SUM: 12 X 100G, 12 X 40G)	2
2.	<b>AGGN NETWORK EQUIPMENT:</b> AGGN network EDGE extension and AAN aggregation switches (SD) 48 X 10G SFP+ ports 4 X 100G QSFP28 ports 1 X Switching Engine, 2 X Power Supply	4
3.	<b>AGGN NETWORK MANAGEMENT EQUIPMENT:</b> AGGN network management switches (MANAGEMENT SIDE) 24 X 1G PoE	1

	4 X 10G SFP+ ports 2 X Power Supply	
4.	<b>AGGN NETWORK MANAGEMENT EQUIPMENT:</b> AGGN to AAN network management switches (MANAGEMENT SIDE) 24 X 1G SFP ports 4 X 10G SFP+ ports 2 X Power Supply	1
5.	<b>AGGN NETWORK MANAGEMENT EQUIPMENT:</b> AGGN network management LTE routers (MANAGEMENT SIDE) 8 X SFP GE ports 8 X 10/100/1000 RJ-45 ports 2 X LTE WAN (upgradable up to 4 LTE WAN ports) 1 X Power Supply	1
6.	<b>ACCESORIES: AGGN NETWORK ACCESSORIES, CABLES AND OTHER CONSUMABLES</b> UTP cable sets AOC/DAC cable sets Optical transceivers included 230V UPS with at least 12h autonomy, 3-phase, 10 kVA, 46 RU height  SUM of AGGN power: 6 KW Active equipment AGGN: 18 RU height	1

**2.2.7.2 AGGN NODE KRANJ – TABLE**

	<b>EQUIPMENT/SERVICE</b>	<b>Quantity</b>
1.	<b>AGGN NODE NETWORK EQUIPMENT:</b> AGGN network EDGE routers 1 X 12 100G QSFP28 ports 2 X 6 40G QSFP ports 2 X Routing Engine, 2 X Power Supply <b>4.8 Tb/s capacity</b> (SUM: 12 X 100G, 12 X 40G)	2
2.	<b>AGGN NETWORK EQUIPMENT:</b> AGGN network EDGE extension and AAN aggregation switches (SD) 48 X 10G SFP+ ports 4 X 100G QSFP28 ports 1 X Switching Engine, 2 X Power Supply	4
3.	<b>AGGN NETWORK MANAGEMENT EQUIPMENT:</b> AGGN network management switches (MANAGEMENT SIDE) 24 X 1G PoE	1

	4 X 10G SFP+ ports 2 X Power Supply	
4.	<b>AGGN NETWORK MANAGEMENT EQUIPMENT:</b> AGGN to AAN network management switches (MANAGEMENT SIDE) 24 X 1G SFP ports 4 X 10G SFP+ ports 2 X Power Supply	1
5.	<b>AGGN NETWORK MANAGEMENT EQUIPMENT:</b> AGGN network management LTE routers (MANAGEMENT SIDE) 8 X SFP GE ports 8 X 10/100/1000 RJ-45 ports 2 X LTE WAN (upgradable up to 4 LTE WAN ports) 1 X Power Supply	1
6.	<b>ACCESORIES: AGGN NETWORK ACCESSORIES, CABLES AND OTHER CONSUMABLES</b> UTP cable sets AOC/DAC cable sets Optical transceivers included 230V UPS with at least 12h autonomy, 3-phase, 10 kVA, 46 RU height  SUM of AGGN power: 6 KW Active equipment AGGN: 18 RU height	1

**2.2.7.3 AGGN NODE NOVO MESTO – TABLE**

	<b>EQUIPMENT/SERVICE</b>	<b>Quantity</b>
1.	<b>AGGN NODE NETWORK EQUIPMENT:</b> AGGN network EDGE routers 1 X 12 100G QSFP28 ports 2 X 6 40G QSFP ports 2 X Routing Engine, 2 X Power Supply <b>4.8 Tb/s capacity</b> (SUM: 12 X 100G, 12 X 40G)	2
2.	<b>AGGN NETWORK EQUIPMENT:</b> AGGN network EDGE extension and AAN aggregation switches (SD) 48 X 10G SFP+ ports 4 X 100G QSFP28 ports 1 X Switching Engine, 2 X Power Supply	4
3.	<b>AGGN NETWORK MANAGEMENT EQUIPMENT:</b> AGGN network management switches (MANAGEMENT SIDE) 24 X 1G PoE	1

	4 X 10G SFP+ ports 2 X Power Supply	
4.	<b>AGGN NETWORK MANAGEMENT EQUIPMENT:</b> AGGN to AAN network management switches (MANAGEMENT SIDE) 24 X 1G SFP ports 4 X 10G SFP+ ports 2 X Power Supply	1
5.	<b>AGGN NETWORK MANAGEMENT EQUIPMENT:</b> AGGN network management LTE routers (MANAGEMENT SIDE) 8 X SFP GE ports 8 X 10/100/1000 RJ-45 ports 2 X LTE WAN (upgradable up to 4 LTE WAN ports) 1 X Power Supply	1
6.	<b>ACCESORIES: AGGN NETWORK ACCESSORIES, CABLES AND OTHER CONSUMABLES</b> UTP cable sets AOC/DAC cable sets Optical transceivers included 230V UPS with at least 12h autonomy, 3-phase, 10 kVA, 46 RU height  SUM of AGGN power: 6 KW Active equipment AGGN: 18 RU height	1

**2.2.7.4 AGGN NODE CELJE – TABLE**

	<b>EQUIPMENT/SERVICE</b>	<b>Quantity</b>
1.	<b>AGGN NODE NETWORK EQUIPMENT:</b> AGGN network EDGE routers 1 X 12 100G QSFP28 ports 2 X 6 40G QSFP ports 2 X Routing Engine, 2 X Power Supply <b>4.8 Tb/s capacity</b> (SUM: 12 X 100G, 12 X 40G)	2
2.	<b>AGGN NETWORK EQUIPMENT:</b> AGGN network EDGE extension and AAN aggregation switches (SD) 48 X 10G SFP+ ports 4 X 100G QSFP28 ports 1 X Switching Engine, 2 X Power Supply	4
3.	<b>AGGN NETWORK MANAGEMENT EQUIPMENT:</b> AGGN network management switches (MANAGEMENT SIDE) 24 X 1G PoE	1



	4 X 10G SFP+ ports 2 X Power Supply	
4.	<b>AGGN NETWORK MANAGEMENT EQUIPMENT:</b> AGGN to AAN network management switches (MANAGEMENT SIDE) 24 X 1G SFP ports 4 X 10G SFP+ ports 2 X Power Supply	1
5.	<b>AGGN NETWORK MANAGEMENT EQUIPMENT:</b> AGGN network management LTE routers (MANAGEMENT SIDE) 8 X SFP GE ports 8 X 10/100/1000 RJ-45 ports 2 X LTE WAN (upgradable up to 4 LTE WAN ports) 1 X Power Supply	1
6.	<b>ACCESORIES: AGGN NETWORK ACCESSORIES, CABLES AND OTHER CONSUMABLES</b> UTP cable sets AOC/DAC cable sets Optical transceivers included 230V UPS with at least 12h autonomy, 3-phase, 10 kVA, 46 RU height  SUM of AGGN power: 6 KW Active equipment AGGN: 18 RU height	1

**2.2.7.5 AGGN NODE MARIBOR – TABLE**

	<b>EQUIPMENT/SERVICE</b>	<b>Quantity</b>
1.	<b>AGGN NODE NETWORK EQUIPMENT:</b> AGGN network EDGE routers 1 X 12 100G QSFP28 ports 2 X 6 40G QSFP ports 2 X Routing Engine, 2 X Power Supply <b>4.8 Tb/s capacity</b> (SUM: 12 X 100G, 12 X 40G)	2
2.	<b>AGGN NETWORK EQUIPMENT:</b> AGGN network EDGE extension and AAN aggregation switches (SD) 48 X 10G SFP+ ports 4 X 100G QSFP28 ports 1 X Switching Engine, 2 X Power Supply	4
3.	<b>AGGN NETWORK MANAGEMENT EQUIPMENT:</b> AGGN network management switches (MANAGEMENT SIDE) 24 X 1G PoE	1

	4 X 10G SFP+ ports 2 X Power Supply	
4.	<b>AGGN NETWORK MANAGEMENT EQUIPMENT:</b> AGGN to AAN network management switches (MANAGEMENT SIDE) 24 X 1G SFP ports 4 X 10G SFP+ ports 2 X Power Supply	1
5.	<b>AGGN NETWORK MANAGEMENT EQUIPMENT:</b> AGGN network management LTE routers (MANAGEMENT SIDE) 8 X SFP GE ports 8 X 10/100/1000 RJ-45 ports 2 X LTE WAN (upgradable up to 4 LTE WAN ports) 1 X Power Supply	1
6.	<b>ACCESORIES: AGGN NETWORK ACCESSORIES, CABLES AND OTHER CONSUMABLES</b> UTP cable sets AOC/DAC cable sets Optical transceivers included 230V UPS with at least 12h autonomy, 3-phase, 10 kVA, 46 RU height  SUM of AGGN power: 6 KW Active equipment AGGN: 18 RU height	1

**2.2.7.6 AGGN NODE CRO WEST – TABLE**

	<b>EQUIPMENT/SERVICE</b>	<b>Quantity</b>
1.	<b>AGGN NODE NETWORK EQUIPMENT:</b> AGGN network EDGE routers 2 X 12 100G QSFP28 ports 2 X 6 40G QSFP ports 2 X Routing Engine, 2 X Power Supply <b>4.8 Tb/s capacity</b> (SUM: 24 X 100G, 12 X 40G)	2
2.	<b>AGGN NETWORK EQUIPMENT:</b> AGGN network EDGE extension and AAN aggregation switches (SD) 48 X 10G SFP+ ports 4 X 100G QSFP28 ports 1 X Switching Engine, 2 X Power Supply	5
3.	<b>AGGN NETWORK MANAGEMENT EQUIPMENT:</b> AGGN network management switches (MANAGEMENT SIDE) 24 X 1G PoE	1

	4 X 10G SFP+ ports 2 X Power Supply	
4.	<b>AGGN NETWORK MANAGEMENT EQUIPMENT:</b> AGGN to AAN network management switches (MANAGEMENT SIDE) 48 X 1G SFP ports 4 X 10G SFP+ ports 2 X Power Supply	1
5.	<b>AGGN NETWORK MANAGEMENT EQUIPMENT:</b> AGGN network management LTE routers (MANAGEMENT SIDE) 8 X SFP GE ports 8 X 10/100/1000 RJ-45 ports 2 X LTE WAN (upgradable up to 4 LTE WAN ports) 1 X Power Supply	1
6.	<b>ACCESORIES: AGGN NETWORK ACCESSORIES, CABLES AND OTHER CONSUMABLES</b> UTP cable sets AOC/DAC cable sets Optical transceivers included 230V UPS with at least 12h autonomy, 3-phase, 10 kVA, 46 RU height  SUM of AGGN power: 6 KW Active equipment AGGN: 19 RU height	1

**2.2.7.7 AGGN NODE CRO EAST – TABLE**

	<b>EQUIPMENT/SERVICE</b>	<b>Quantity</b>
1.	<b>AGGN NODE NETWORK EQUIPMENT:</b> AGGN network EDGE routers 2 X 12 100G QSFP28 ports 2 X 6 40G QSFP ports 2 X Routing Engine, 2 X Power Supply <b>4.8 Tb/s capacity</b> (SUM: 24 X 100G, 12 X 40G)	2
2.	<b>AGGN NETWORK EQUIPMENT:</b> AGGN network EDGE extension and AAN aggregation switches (SD) 48 X 10G SFP+ ports 4 X 100G QSFP28 ports 1 X Switching Engine, 2 X Power Supply	5
3.	<b>AGGN NETWORK MANAGEMENT EQUIPMENT:</b> AGGN network management switches (MANAGEMENT SIDE) 24 X 1G PoE	1

	4 X 10G SFP+ ports 2 X Power Supply	
4.	<b>AGGN NETWORK MANAGEMENT EQUIPMENT:</b> AGGN to AAN network management switches (MANAGEMENT SIDE) 48 X 1G SFP ports 4 X 10G SFP+ ports 2 X Power Supply	1
5.	<b>AGGN NETWORK MANAGEMENT EQUIPMENT:</b> AGGN network management LTE routers (MANAGEMENT SIDE) 8 X SFP GE ports 8 X 10/100/1000 RJ-45 ports 2 X LTE WAN (upgradable up to 4 LTE WAN ports) 1 X Power Supply	1
6.	<b>ACCESORIES: AGGN NETWORK ACCESSORIES, CABLES AND OTHER CONSUMABLES</b> UTP cable sets AOC/DAC cable sets Optical transceivers included 230V UPS with at least 12h autonomy, 3-phase, 10 kVA, 46 RU height  SUM of AGGN power: 6 KW Active equipment AGGN: 19 RU height	1

## 2.2.8 AAN NODE

Access – Active Access Node presents OLT device which should have 2 upstream (10GE or 40GE/100GE) ports and 16 or less downstream ports – PON ports depend of type of PON device.

In case of RUNE project customer want to focus to the ITU-T standard PON technology - GPON (ITU-T G.984) and XGS-PON (ITU G.9807.1, 2016).

AAN node should have dual-homed connection towards 2 access ports in 2 different locations of AGGN device. GPON OLT device need to have two (2) 10GE ports, XGS-PON OLT device should have two (2) 40GE ports or 100GE ports as an upgrade option.

AAN need to support all major L2 features including QinQ, IGMPv2 and IGMPv3, MAC Bridges, DHCP Relay Agent and service classification based per port , S-VLAN-ID, C-VLAN-ID and p-bit.

Figure 9 shows the connectivity diagram of the AAN node and typical upstream connection speeds available today (100G speed is available as an upgrade in the future).

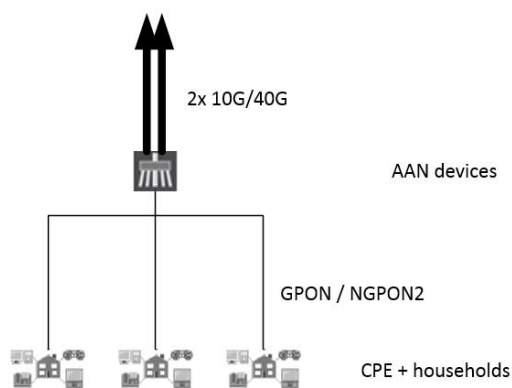

Figure 9: AAN node interconnect

### 2.2.8.1 AAN NODE

	EQUIPMENT/SERVICE	Quantity
1.	<b>AAN NETWORK EQUIPMENT:</b> AAN-AGGN network management L2/L3 device (MANAGEMENT SIDE) 2 X SFP GE ports 6 X 10/100/1000 RJ-45 ports 1 X Power Supply Fanless (no rotating parts for cooling)	120
2.	<b>ACCESORIES:</b> <b>AGGN NETWORK ACCESSORIES, CABLES AND OTHER CONSUMABLES</b> UTP cable sets Optical transceivers included 230V UPS with at least 12h autonomy, 1-phase, 3 KVA, 28 RU height  SUM of AAN power: 690 W Active equipment AGGN: 7 RU height	120

Figure 10 provides the view of logical connectivity from end user to ISPCN node.

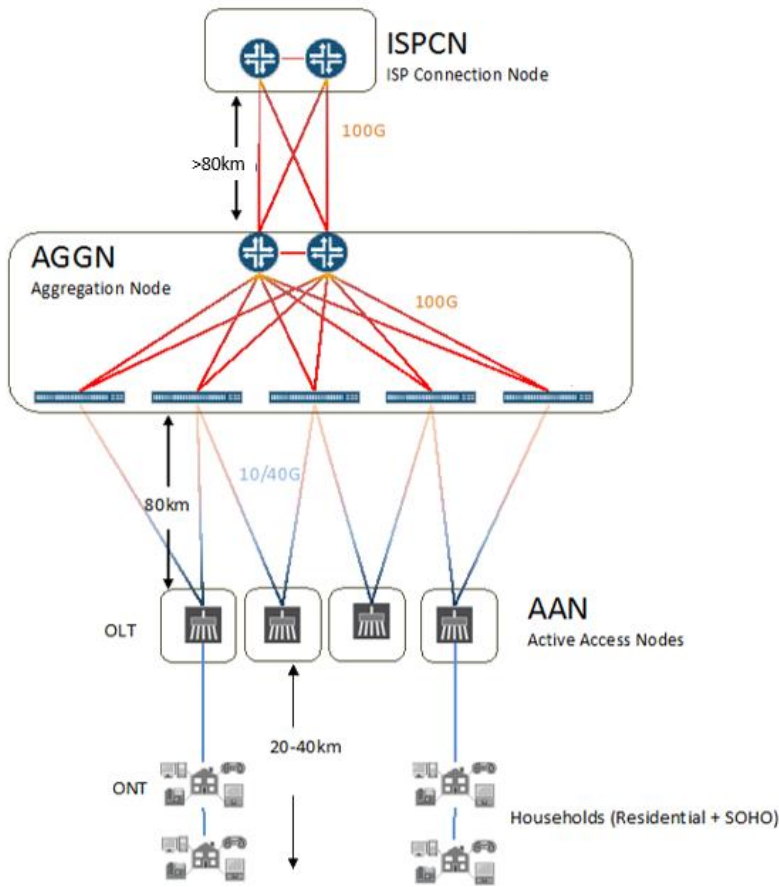

Figure 10: Logical Vertical Network Topology

## 2.2.9 OPTICAL TRANSPORT SYSTEM

### 2.2.9.1 OPTICAL TRANSPORT SYSTEM BETWEEN AGGN AND ISPCN NODES

Optical transport system should be carefully designed with low-level design. At least two independent leased fibre connections between AGGN and ISPCN nodes are planned at the first stage. Proposed solution is to use optical transponders with additional amplifiers and CFP2 DWDM 100 Gbit/s modules for optical transport as it can only enable long-haul connectivity on leased optical fibre. Interconnection between all ISPCN nodes (2x in Slovenia and 2x in Croatia) will take the same solution.

On a long term with 100G technology improvement and price drop it would be possible to use direct »grey« optics or DWDM interfaces for direct connections of AGGN nodes to core networks. This presumption is based on the following:

- 100G interfaces will become mature technology, widely used and also with better capabilities than today
- RUNE Company will deploy during project a major quantity of own optical high-quality fibres allowing solution providers to take maximum advantage of its technical capabilities with most recent 100G interfaces of moderate price. In this way network capabilities will be increased reasonably and upon real utilization request.

Optical transport system should meet following requests:

- Initial 2 X 200 Gb/s capacity between AGGN and ISPCN at the network set-up
- Possible upgrade to 2 X 400 Gb/s, 4 X 200 Gb/s or more without new passive optical elements (all optical filters already installed). Upgrade without existing service interruption.
- Long Haul DWDM system is providing primary interconnections between AGGNs and ISPCNs at the distance of 100 to 150 km
- Long Haul DWDM system is able to deliver at least 2 X 200 Gb/s per zone (7 zones = **7 DWDM systems**), with upgrade option to at least 4 X 200 Gb/s
- Long Haul DWDM system interconnecting Slovenian and Croatian ISPCN core networks (**4 DWDM systems**) at the distance of 150 km to 200 km
- Support for 40 DWDM channels MUX/DEMUX with channel spacing ITU 50GHz Grid must be provided

Within the AGGN and ISPCN nodes interconnections will be implemented using AOC cables or short-range QSFP28 100 Gbit/s modules.

2.2.9.2 OPTICAL TRANSPORT SYSTEM BETWEEN AAN AND AGGN NODES

Connection between AGGN and beyond towards AAN will take private optical fiber network. Grey SFP+ or QSPF28 40 Gbit/s and 100 Gbit/s will be used in this case.

WDM multiplexing is possible, which minimizes number of needed fibres although there will be enough optical fibers available at every location.

Figure 11 is showing the way in which WDM multiplexing can be used.

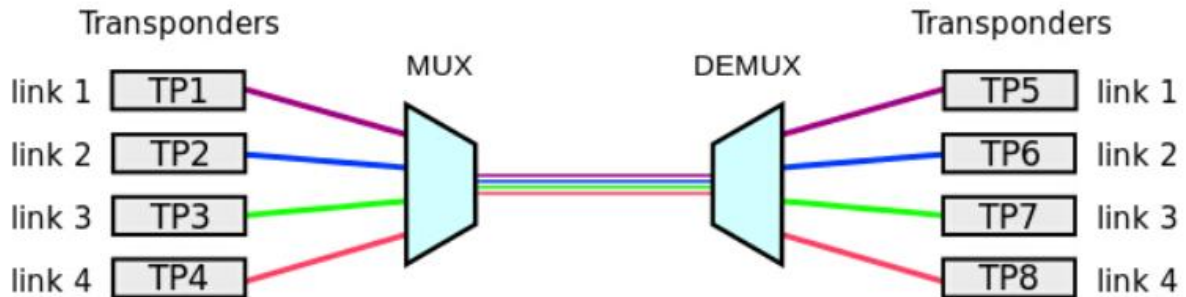

Figure 11: WDM system

CWDM enables up to 18 channels with wavelengths between 1270nm and 1610nm via Dual Fibre CWDM Mux Demux, but only 8 upper channels are feasible of communicating on long distances.

With typical insertion loss of 3 dB (8channel filter) and 28 dB power budget of 10G CWDM SFP+ optical transceiver maximum distance of passive CWDM can be about 80km.

DWDM enables 40 or 80 channels and can go up to 96 channels with wavelengths between 1530nm and 1625nm. Amplification enables transmission of data over longer distances. Power requirements for DWDM system are higher due to the technology itself. Depending on the DWDM technology used power budget (PB), chromatic dispersion (CD) and polarized mode dispersion (PMD) can be a limitation on longer distances. Channel spacing in DWDM is narrower than on CWDM technology and solutions must include proper design in order to provide working conditions for all the channels in the system.

With typical insertion loss of 3.5 dB (40channel filter) and 28 dB power budget of 10G DWDM SFP+ optical transceiver maximum distance of passive DWDM can be about 60km.

Advantage of designing the system with grey-SFP's is predictability of the solution at the moment, as low-level network planning is needed to set-up DWDM/WDM fibre systems.

Figure 12 is showing the links between AGGNs and ISPCNs where DWDM solution will be required capacity.



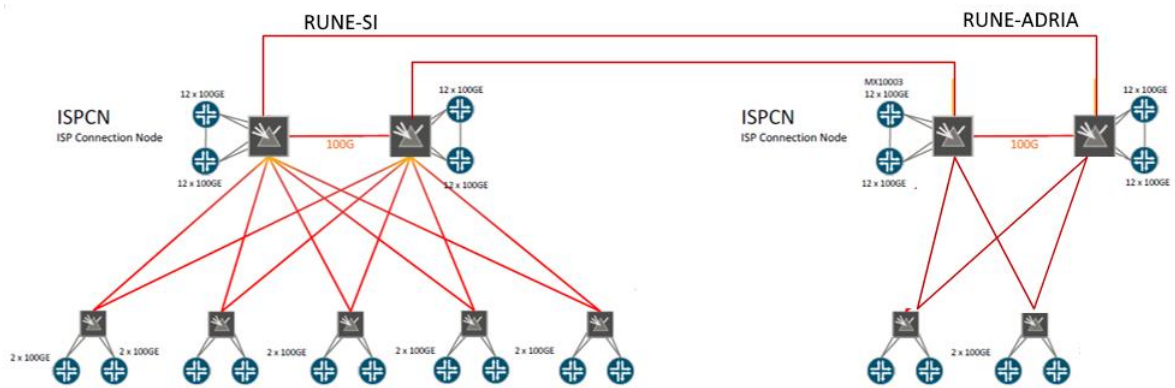

Figure 12: DWDM topology, each red color link has capacity of 200GE (upgradeable to 400GE)

Optical network controller should be possible to be used as a standalone NMS system or as a “domain controller” inside a full SDN architecture.

Network management system of optical transport system should have the following functionalities and capabilities:

- Alarm surveillance
- Geographical view of the nodes and view of network elements
- Management of connections (Path set-up and routing)
- Performance Monitoring
- Logs

Following standardized interfaces for SDN the architecture should be supporting:

- Southbound interface:
  - RESTconf with ONF Yang model for management of the devices
- Northbound interface:
  - RESTconf with ONF T-API (Transport API)

	EQUIPMENT/SERVICE	Quantity
1.	<b>DWDM PTP SYSTEMS</b> Long Haul DWDM system 2 X 200G or 4x 100G Hardware upgradable to 4x 200G or 8x 100G 200 Km reach 4 X QSFP28 LAN side 2 X CFP WAN side 40-channel MUX/DEMUX filter 1 X management port Management software included Optical transceivers included <b>800 Gb/s capacity</b>	18 pairs

## 2.2.10 MANAGEMENT SYSTEM

Network Management platform(s) must work with management applications to simplify and automate configuration and management of optical transport devices as well as core and aggregation network’s

switching and routing devices. As part of whole system the platform provides fault, configuration, accounting, performance, and security management capability, support for new devices and new software releases, a task-specific user interface, and northbound APIs for integration with other network management systems (NMS) or operations/business support systems (OSS/BSS).

Network management platform allows network operations, reduces complexity, and enable new applications and services to be brought to system quickly, through multi-layered network abstractions, operator-centric automation schemes, and a simple point-and-click user interface.

Other features are unified approach to manage a core and aggregation network infrastructure and design and deploy new services. Centralized management and orchestration of network devices and services need to be brought through a unified display for real-time visibility.

Network Management platform has ability to extend to third parties through RESTful APIs. Its functionalities have to be accessed through a GUI that uses workflows per-user and progressive disclosure to enable operator-centric and scope-specific visibility and control. Its ability must support and cover the most important transport network capabilities:

- Design, provisioning, activation, and validation of RSVP-signalled label-switched paths (LSPs),
- Design, provisioning, activation, and validation of L2/L3 VPNs across MPLS and Carrier Ethernet networks
- Design and provisioning of quality-of-service (QoS) profiles for services
- Service troubleshooting, service statistics, and performance measurement using the ITU Y.1731 specification
- Chassis views for configuration and services monitoring
- RESTful-based API should allow network providers to completely automate service provisioning and effectively position their networks for future SDN and Network Functions Virtualization (NFV) architectures

All network elements and subsystems must be fully manageable and supervised via central single-point allowing also for transparent monitoring and alerting.

All management systems must be fully redundant across the entire network including Slovenian and Croatian part.

### 2.2.11 NETWORK MANAGEMENT SYSTEM FEATURES

Network management system should provide following features for automated end-to-end connectivity:

- Auto-discovery of network devices
- Automated MPLS and network resource management by using predefined network signatures that help with MPLS role and VLAN ID pools assignment.
- Service designers can customize a carrier's predefined service offering designs and E-LINE and ELAN-VPLS services
- Multi-homing of VPLS connected customer sites to multiple PE routers
- Simple provisioning enables operators to easily select the endpoints for activating a customer VPN, which removes all possible manual configuration errors
- Configuration pre- and post-validation and operational validation
- Performance monitoring provides early warning about network problems and allows service providers to meet SLA

- OSS / BSS integration offers REST API for northbound OSS/BSS to achieve platform extensibility, multivendor support and service orchestration.

### 2.2.12 MANAGEMENT NETWORK OF ISPCN NODE

Redundant in-band and out-of-band management connection to any device in the designed AGGN and CORE network is required. Secure connections for authorized administrators from the public Internet need to be terminated on Next Generation Firewall with IPSec / SSL capabilities. Next Generation Firewall for remote access is installed in every ISPCN node. Routing protocols enable availability of any network resource inside AAN, AAGN and ISPCN nodes.

Two “VPN” redundant routers are installed in every ISPCN node for enabling secure connectivity between ISPCN management networks and AGGN management networks. Two redundant logical connections should be available between ISPCN and AGGN management networks, one via private optical network and another via public Internet.

Out-of-band L2/L3 gigabit switch is needed to connect to any management port of network devices inside the nodes. Also PoE capabilities are needed to power video surveillance devices and any other PoE powered device.

Figure 13 is providing the topology of the management solution in the ISPCN nodes.

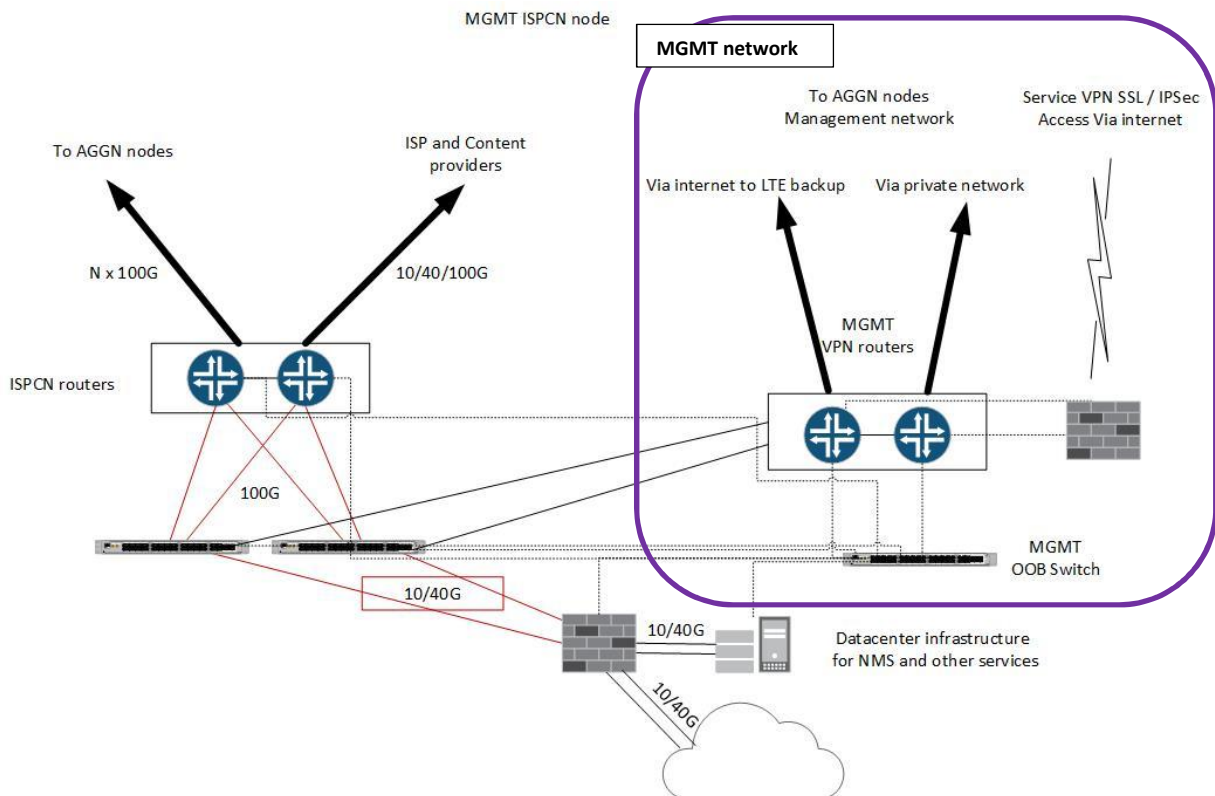

Figure 13: Management network ISPCN node

### 2.2.13 MANAGEMENT NETWORK OF AGGN AND AAN NODE

A VPN router is set-up in every AGGN node for enabling secure connectivity between ISPCN management networks and AGGN management networks. Two redundant logical connections should be available between ISPCN and AGGN management networks, one via private optical network and redundant via LTE cellular network.

Out-of-band L2/L3 gigabit switch is needed to connect to any management port of network devices inside the nodes. Also PoE capabilities are needed to power video surveillance devices and any other PoE powered device.

Another L2/L3 gigabit switch is needed to connect all AAN management devices in the same zone via gigabit optical link.

L2/L3 device is requested on each AAN with optical gigabit uplink to AAGN node.

Figure 14 is providing the topology of the management solution in the AGGN and AAN nodes.

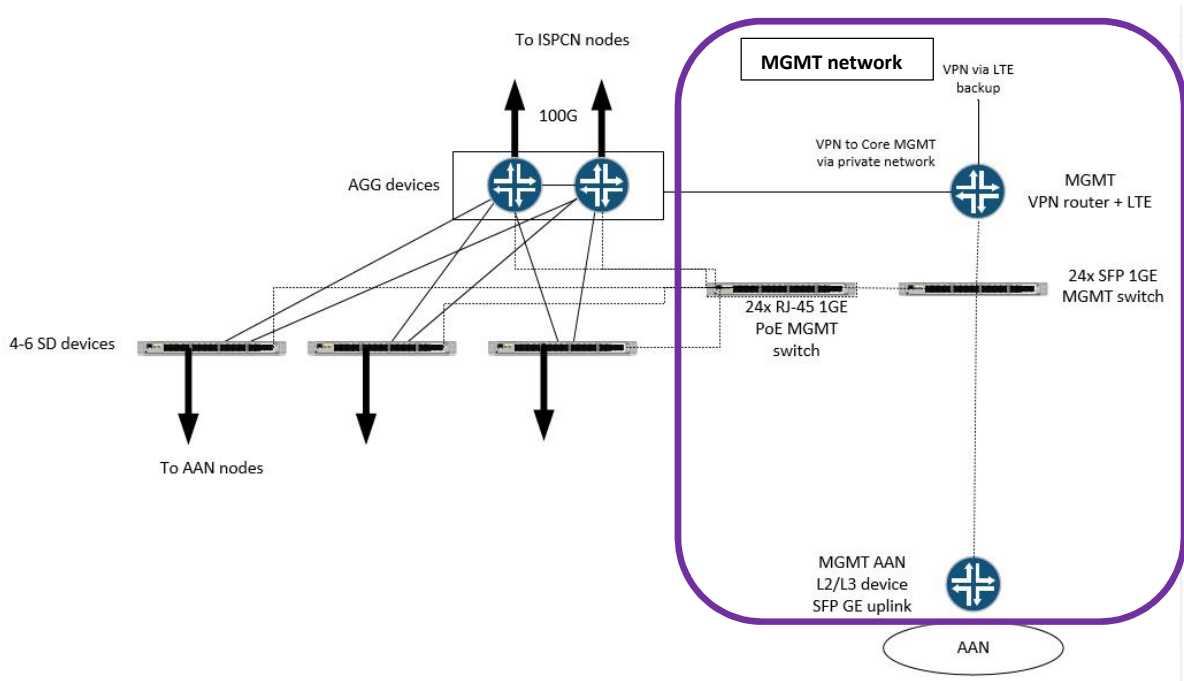

Figure 14: Management network AGGN and AAN nodes

#### 2.2.14 END-USER ACCESS MANAGEMENT

An end-user access environment includes various components – end-user access technologies and authentication protocols.

The end-user access technologies include DHCP, DNS server and authentication, authorization, and accounting (AAA) protocols, offered by the RADIUS server. End-user policy enforcement must be applied.

DHCP and DNS service in optical access networks provide IP address configuration and service provisioning.

Single point of DHCP service control should be in a datacentre. Address assignment pools are defined, from which to allocate end-user addresses. Dynamic address assignment and static address assignment of IP addresses from pre-defined address assignment pools is possible.

Above mentioned services are necessary to enable RUNE offered captive portal.

Captive portal is a web page, where end-user is given different infrastructure status information. Captive portal offers end-user the choice between different service and content providers.

End-user access management services need to be integrated with the database of existing end-user subscriptions. Integration into Operational Support Systems (OSS) and Business Support Systems (BSS) has to be done as well.







### 3. PROJECT SCHEDULE

Project schedule is already foreseen for 7 years' time period.

Bidder must be aware about unknown project dynamics and must therefore plan for all project expenses, resources and schedule according to such wide time frame window activities.

Detailed project schedules will be planned on real basis in cooperation with customer.

#### 4. ADDENDA

 Juinper_MX_10003_1000619-en.pdf	Juniper MX 10003 Datasheet
 Juniper_QFX5110_1000605-en.pdf	Juniper QFX 5110 Datasheet
 Juniper_Fusion_Business_Value_MX.pdf	Juniper Fusion technology
 NMS_Junos_Space_1000297-en.pdf	Juniper Space NMS
 NMS_Junos_Space_CSD_1000530-en.pdf	Juniper Space NMS Connectivity Services Director
 SM_OPTICS-LM-1 OTN draft datasheet	SM Optics LM1 OTN Datasheet
 SM_OPTICS-product catalog 02-17 v1.pdf	SM Optics Product Catalogue 2017